



PRIANERA®

## PRIANERA

Un Brand deve avere una storia, un messaggio autentico da comunicare. Prianera è il Brand di Polaris. Pria Nera è il nome originario della matita, comparso per la prima volta in Italia nel Quattrocento. La matita creativa del designer che diventa la matita esperta del modellista nel creare sagome di cartone per ogni modello e infine la matita attenta dell'artigiano nel trasferire ogni sagoma sui manti delle migliori pelli. La vera bellezza è quella creata dalla mente e realizzata con le mani. Stile, unicità, ricerca, tradizione, innovazione, in una cornice tutta italiana. Questo è Prianera.

Cennino di Andrea Cennini (Colle di Val d'Elsa, 1370 – Firenze, 1440) è stato un pittore italiano influenzato da Giotto, allievo per una dozzina d'anni di Agnolo Gaddi e noto per aver scritto in volgare all'inizio del XV secolo un trattato sulla pittura "Il Libro dell'arte".

A Brand must have a story, an authentic message to tell. Prianera is the Brand for Polaris. Pria Nera is the original name of the pencil, used for the first time in Italy in the XV century. The Creativity of the pencil of a designer continues in the Experience of the pencil of a modeller in creating the cardboard cutouts which compose each model. And then a Careful pencil follows these cutouts to select the best parts of each leather. The real beauty is the one created by the mind and carried out by the hands. Style, distinctiveness, research, tradition, innovation, in a whole Italian setting. This is Prianera.

Cennino of Andrea Cennini (Colle di Val d'Elsa, 1370 – Firenze, 1440) a pupil for a dozen years of Agnolo Gaddi, is an Italian painter influenced by Giotto and known for writing in vernacular at the beginning of the XV century an essay about painting, "Il Libro dell'Arte" (The Book of the art).



*"Ancora per disegnare ho trovata  
certa pria nera, che vien del Piemonte,  
la quale è tenera pria;  
e puo'la aguzzare con coltellino,  
chè ella è tenera e ben negra;  
e puo' ridurla a quella perfezione che  
l' carbone.  
E disegna secondo che vuoi".*



Uno degli strumenti scrittori più antichi è lo stilo, la cui punta affilata permetteva la stesura grafica. Lo vediamo in un affresco pompeiano, in cui la poetessa Saffo si appresta a scrivere uno dei componimenti poetici che la resero celebre. Se allora lo stilo era utilizzato per scrivere, in seguito il suo impiego fu esteso al disegno. A partire dal secondo Quattrocento nel Nord e Centro Italia ebbe particolare successo la matita nera, chiamata anche "pietra nera" o "pietra d'Italia", un materiale naturale (scisto argilloso o carbonifero) proveniente dai giacimenti del Piemonte, già conosciuto ai tempi di Cennini, ma allora ancora poco usato, almeno in Toscana. Se ne ricavano piccole asticcioline da temperare, e la sua duttilità permetteva di ottenere sia dettagli precisi, se la punta veniva affilata, sia, se usata di piatto, effetti atmosferici con morbide gradazioni tonali.

One of the most ancient writing tools is the stylus, whose sharp tip allows the drafting graphics. We see it in a fresco at Pompei, where the poetess Saffo is shown while preparing to write one of the poems that made her famous. If at that time the stylus was used to write, afterward its use has been extended to the drawing. From the second part of the XV century in the North-Central area of Italy the black pencil, also called "pietra nera" (black stone) or "pietra d'Italia" (stone of Italy), obtained a great success. It was a natural material (shale or coal) coming from the fields of the region Piemonte, already known at the time of Cennini, but then still little used, at least in Tuscany. They obtained small rods to be sharpened, and its flexibility allowed both precise details, if the tip was sharpened, and atmospheric effects with smooth tonal gradations, if used flat.



**Sandro Botticelli, Ninfa accompagnata da putti, 1480-1485 ca, inchiostro e pietra nera, British Museum, Londra**  
Sandro Botticelli, Nymph accompanied by putti ca. 1480-1485, pen and ink, brush and black stone, British Museum, London

La gamma di proposte del catalogo Prianera mantiene come elemento distintivo lo stretto legame con l'attualità, dimostrando una profonda capacità di cogliere le esigenze e i gusti di un pubblico eterogeneo e internazionale. Uno degli elementi fondamentali che determinano la crescita e l'affermazione di Prianera sta nell'apporto creativo di molti importanti designer che hanno collaborato e collaborano con l'azienda, tra gli altri, Dino Savasta, Rodolfo Bertozzi, Carlo Bimbi, Fabrizio Ballardini, Giorgio Ragazzini, Carlo Sironi, Angelo Tomaiuolo ed Enrico Cesana.

The range of products in the Prianera catalogue has its distinctive feature in its tight connection with modernity, showing its strong ability to understand the needs and trends of an international public. One of the main elements that determine the growth and success of Prianera lies in the creative contribution of many renowned designers, who have been collaborating with the company, such as Dino Savasta, Rodolfo Bertozzi, Carlo Bimbi, Fabrizio Ballardini, Giorgio Ragazzini, Carlo Sironi, Angelo Tomaiuolo and Enrico Cesana.

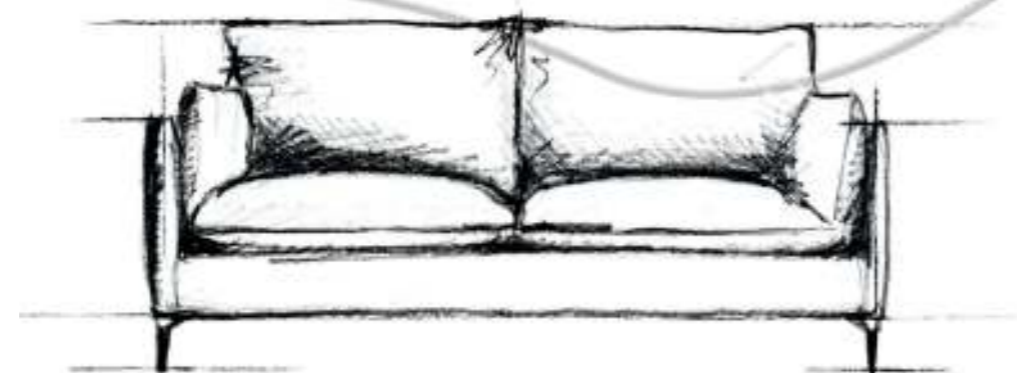

L'azienda dedica un'incessante attività alla quotidiana ricerca dell'equilibrio tra bellezza del lavoro eseguito a mano secondo la tradizione e l'indubbio vantaggio e affidabilità del ricorso alle più moderne tecnologie. Ogni cucitura ed ogni piega sono lavorati con maestria per ottenere il miglior risultato possibile. Ogni modello rappresenta l'impegno aziendale per la valorizzazione del prodotto italiano nel mercato globale. Con competenza, attenzione, ricerca continua e lavoro costante, Prianera esprime tutta l'esperienza di una produzione sinonimo di qualità e stile italiano. Ogni prodotto viene costruito con cura e attenzione e ogni singolo divano passa attraverso svariate fasi di lavorazione e controllo completamente artigianali. Abili mani si impegnano giornalmente nella produzione senza lasciare nulla al caso e soprattutto senza trascurare tutti quei piccoli dettagli che contraddistinguono i prodotti Prianera.

The company dedicates an unceasing activity to the daily research for balance between the beauty of work made by hand according to tradition, and the undeniable advantage and reliability of the latest technologies. Every single stitching and every single fold are masterly crafted in order to obtain the best possible result. Each model is emblem of the commitment of the company to give value to the Italian product on the global market. With expertise, care, constant research and work, Prianera represents the long experience of a production that is synonym for high quality and Italian style. Every product is handmade with care and attention, and every single sofa is the result of numerous, entirely artisan manufacturing and control phases. Skilled hands work hard every day on the production, leaving nothing to chance and, above all, without neglecting all those details that distinguish the Prianera products.

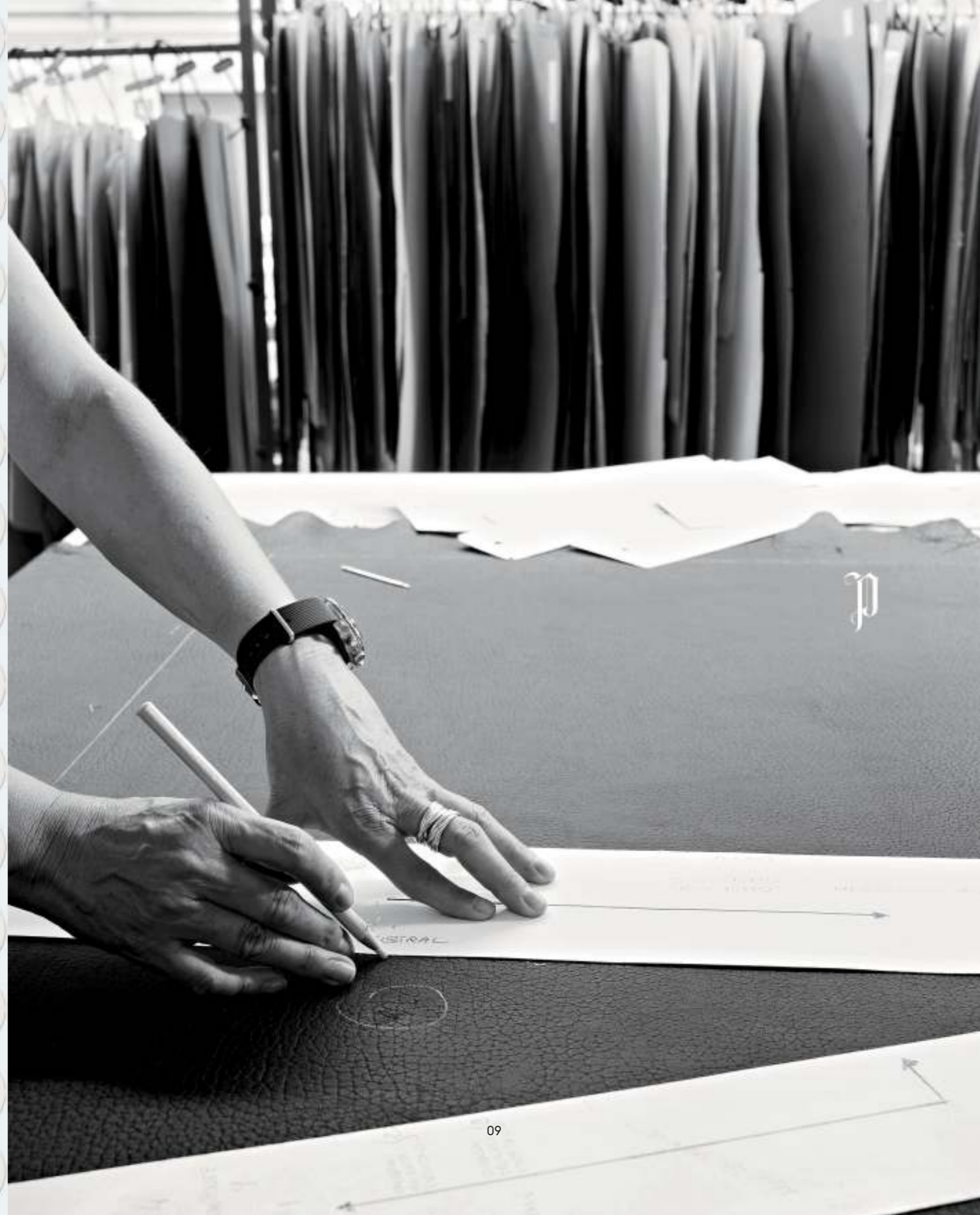

P



**il vasto magazzino di pelli di altissima qualità propone diverse categorie di prezzo e tipologia, insieme a coloriture sempre aggiornate**  
our leather wide warehouse, with large and top quality sizes can supply different category of prices and types, along with always updated colors



**è nella fase del cucito che Polaris esprime al meglio le proprie qualità produttive: con cuciture curate e ben allineate, il prodotto risulta vestito in modo impeccabile**  
Polaris enhances its production quality in the sewing phase, the seams are accurate, aligned and as a result the sofa is dressed in a flawless way

P



**il lavoro di assemblaggio è realizzato manualmente da esperti artigiani, una particolare attenzione è poi dedicata alla fase di controllo di ogni singolo divano finito**  
the assembling work is done manually by skilled artisans, a great care is given to the last control phase on each single sofa produced

## MADE IN ITALY

Polaris designed for living srl esprime nel brand Prianera tutta l'eredità della famiglia dei fondatori dell'azienda. L'esperienza acquisita nei decenni di attività del proprio personale, il loro impegno e la loro passione contraddistinguono la qualità dei prodotti ed il carattere di un'idea coraggiosa rivelatasi un successo: mantenere viva la qualità del lavoro manuale e la vocazione di un territorio, in un contesto tutto italiano, a Forlì, all'interno di una produzione di design.

With its brand Prianera, Polaris designed for living srl expresses the heritage of the family who founded the company. All the experience that the staff acquired during the decades of activity, together with their commitment and passion, distinguish the quality of its products and the strong character of a daring idea that revealed itself a great success: keeping alive the quality of craftsmanship and the vocation of the territory, through a design production, in an exclusively Italian setting.







## INDICE INDEX

<b>134</b>	ALIANTE
<b>144</b>	ARIEL
<b>32</b>	BERNINI
<b>176</b>	CANOVA
<b>160</b>	DAYTIME
<b>152</b>	FELIX
<b>104</b>	GLAMOUR
<b>166</b>	MALAGA
<b>40</b>	MAYA
<b>52</b>	MIVIDA
<b>18</b>	MODÍ
<b>98</b>	MOOD
<b>118</b>	NESTING
<b>90</b>	NILO
<b>80</b>	SHARPEI
<b>114</b>	SONORA
<b>170</b>	SORRENTINO
<b>128</b>	TANGRAM UP
<b>62</b>	VEGA
<b>72</b>	YUCATAN
<b>180</b>	COMPLEMENTI

MODÌ

Design Style Department Prianera



SHARPEI pelle/leather Nabuk cacao 5012  
cuscini ricamati esclusivi/exclusive embroideries cushions Prianera  
Tappeto/carpet MASH-UP turchese  
Wallpaper SCREEN mocha







**MODi** pelle/leather Stonewash Pro ecrù 6002  
filetto in pelle/piping in leather Nabuk cacao 5012  
cuscini ricamati esclusivi/exclusive embroideries cushions Prianera

MODÌ

Design Style Department Prianera

P

ALICE tessuto/fabric Velluto Splendido blu notte - Dedar  
filetto in tessuto/piping in fabric Bloom 02  
Tappeto MASH-UP blu





MODÌ pelle/leather Loden topo  
filetto in tessuto/piping in fabric in Bloom 02  
cuscino/cushion Velluto Splendido blu notte - Dedar



**BERNINI**

Design Style Department Prienera

P

FLORENCE pelle/leather Nabuk verde scuro 5022  
Tappeto LEAF verde

BERNINI pelle/leather Stonewash Pro forestale 6031  
bracciali e cuscini/armrests and cushions  
ricamati esclusivi/exclusive embroideries Prienera



# BERNINI

Design Style Department Prianera

P





**BERNINI** pelle/leather Bost bianco 3144  
cuscini ricamati esclusivi/exclusive embroideries cushions Prianera  
Tappeto/carpet LEAF sabbia  
Wallpaper WILD lunar

MAYA

Design Style Department Prianera



MAYA pelle/leather Georgia tortora 3209

WEBY tessuto/fabric Saint Moritz col. 139



MAYA - pelle/leather Stonewash Pro antracite 6050  
cuscini ricamati esclusivi/exclusive embroideries cushions Prianera  
Tappeto/carpet FRAME cipria  
Wallpaper SCREEN cloud





MAYA pelle/leather Stonewash Pro light grey 6003  
tessuto/fabric Saint Moritz col.10



MAYA

Design Style ... t Prian



P

MAYA - pelle/leather Georgia amianto 3208  
cuscini in tessuto/cushions in fabric in Velluto Nobilis  
Coffee table ROUND - LIBRIS







P

# MIVIDA

Design Angelo Tomaiuolo

P





MIVIDA tessuto/fabric Polly 31  
filetto/piping Polly 30  
cuscino/cushion Velluto Nobilis  
basamento in legno/wooden base col. noce fume  
Coffee table ROUND



P

# MIVIDA

Design Angelo Tomaiuolo



58



MIVIDA pelle/leather Stonewah Pro africa 6046  
basamento in legno/wooden base col. noce fumè



VEGA

Design Style Department Prianera



P





VEGA pelle/leather Stonewash Pro light grey 6003  
tessuto/fabric Wow 06 - Dedar  
corner in Luxury 320  
cuscini ricamati esclusivi/exclusive embroideries cushions Prianera  
Tappeto/carpet BIG LOGO Tufted red



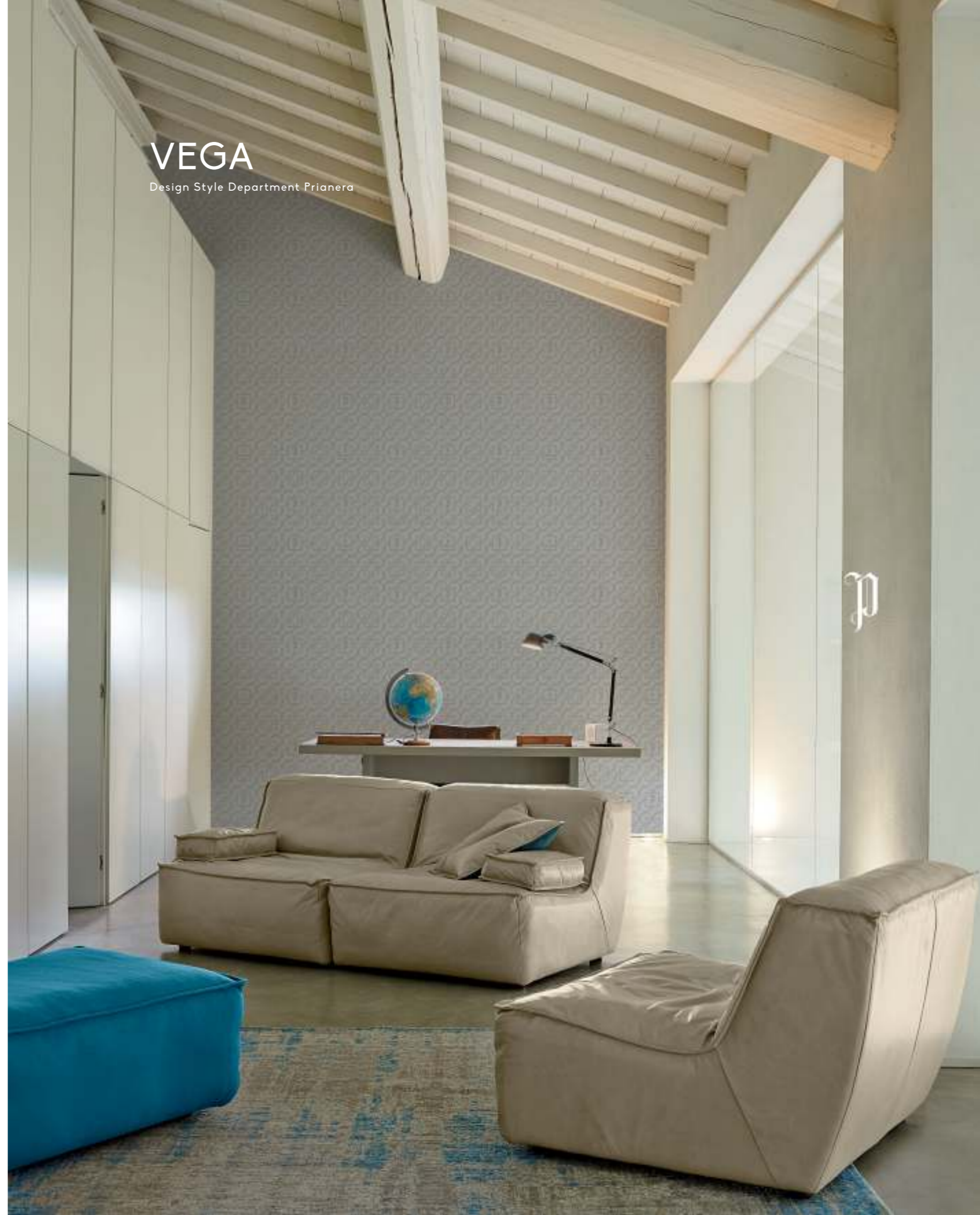



VEGA pelle/leather Stonewash Pro light grey 6003  
tessuto/fabric Europost 67066  
Wallpaper SCREEN cloud

# YUCATAN

Design Fabrizio Ballardini





YUCATAN pelle/leather Georgia amianto 3208  
cuscini/cushions  
pelle/leather Georgia amianto 3208 - Nabuk stone 5086







SHARPEI

Design Fabrizio Ballardini





**SHARPEI** pelle/leather Nabuk cacao 5012  
cuscini ricamati esclusivi/exclusive embroideries cushions Prianera  
Tappeto/carpet MASH-UP turchese  
Wallpaper SCREEN mocha

# SHARPEI

Design Fabrizio Ballardini





SHARPEI pelle/leather Nabuk stone 5086



P

# NILO

Design Fabrizio Ballardini





NILO pelle/leather Bosphore bianco 4044  
Braccioli e cuscini/armrests and cushions  
ricamati esclusivi/exclusive embroideries Prianera

NILO

Design Fabrizio Ballardini



P







NILO pelle/leather Georgia amianto 3208

# MOOD

Design Fabrizio Ballardini





MOOD pelle/leather Stonewash Pro antracite 6050  
Coffee table FREELINE



# GLAMOUR

Design Carlo Bimbi







# GLAMOUR

Design Carlo Bimbi







# SONORA

Design Fabrizio Ballardini



D



SONORA pelle/leather Bosphore stone 4209  
KLAB tessuto/fabric Europost 66119 - 66056

# NESTING

Design Enrico Cesana





**NESTING** versione tappezzata/upholstred version  
cucitura spaccata/rough hem stitching  
pelle/leather Nabuk stone 5086 - verde scuro 5022



**NESTING** versione tappezzata/upholstred version  
cucitura spaccata/rough hem stitching  
pelle/leather Nabuk verde scuro 5022  
cuscini in tessuto/fabric in fabric Europost

# NESTING

Design Enrico Cesana



NESTING versione standard/standard version  
cucitura spaccata/rough hem stitching  
pelle/leather Sequoia carbone 4004





# TANGRAM UP

Design Enrico Cesana







# ALIANTE

Design Fabrizio Ballardini

P





**ALIANTE** pelle/leather Georgia amianto 3208  
filetto in tessuto/piping in fabric Velluto Nobilis 24  
**NORA** tessuto/fabric Velluto Nobilis 10



# ALIANTE

Design Fabrizio Ballardini





P

**ALIANTE** pelle/leather Sequoia cioccolato 4002  
filetto in tessuto/piping in fabric Saint Moritz 69  
**NORA** tessuto/fabric Saint Moritz 69





# ARIEL

Design Fabrizio Ballardini





ARIEL pelle/leather Georgia topo 3210



P



ARIEL tessuto/fabric Polly 30

# FELIX

Design Carlo Bimbi & Carlo Sironi







# FELIX

Design Carlo Bimbi & Carlo Sironi



# DAYTIME

Design Carlo Bimbi & Carlo Sironi





DAYTIME pelle/leather Georgia zinco 3286  
KAREN pelle/leather Actual polvere 6003



# MALAGA

Design Rodolfo Bertozzi





# SORRENTINO

Design Style Department Prianera





SORRENTINO pelle/leather Bosphore amianto 4208  
KAREN tessuto/fabric Amore 66





# CANOVA

Design Style Department Prianera





# FLORENCE

Design Style Department Prianera



# KAREN

Design Carlo Bimbi & Carlo Sironi



# ALICE

Design Carlo Bimbi & Carlo Sironi



# WEBY

Design Fabrizio Ballardini



# NORA

Design Fabrizio Ballardini





# KLAB

Design Carlo Bimbi & Carlo Sironi



# LOTO

Design Carlo Bimbi & Carlo Sironi

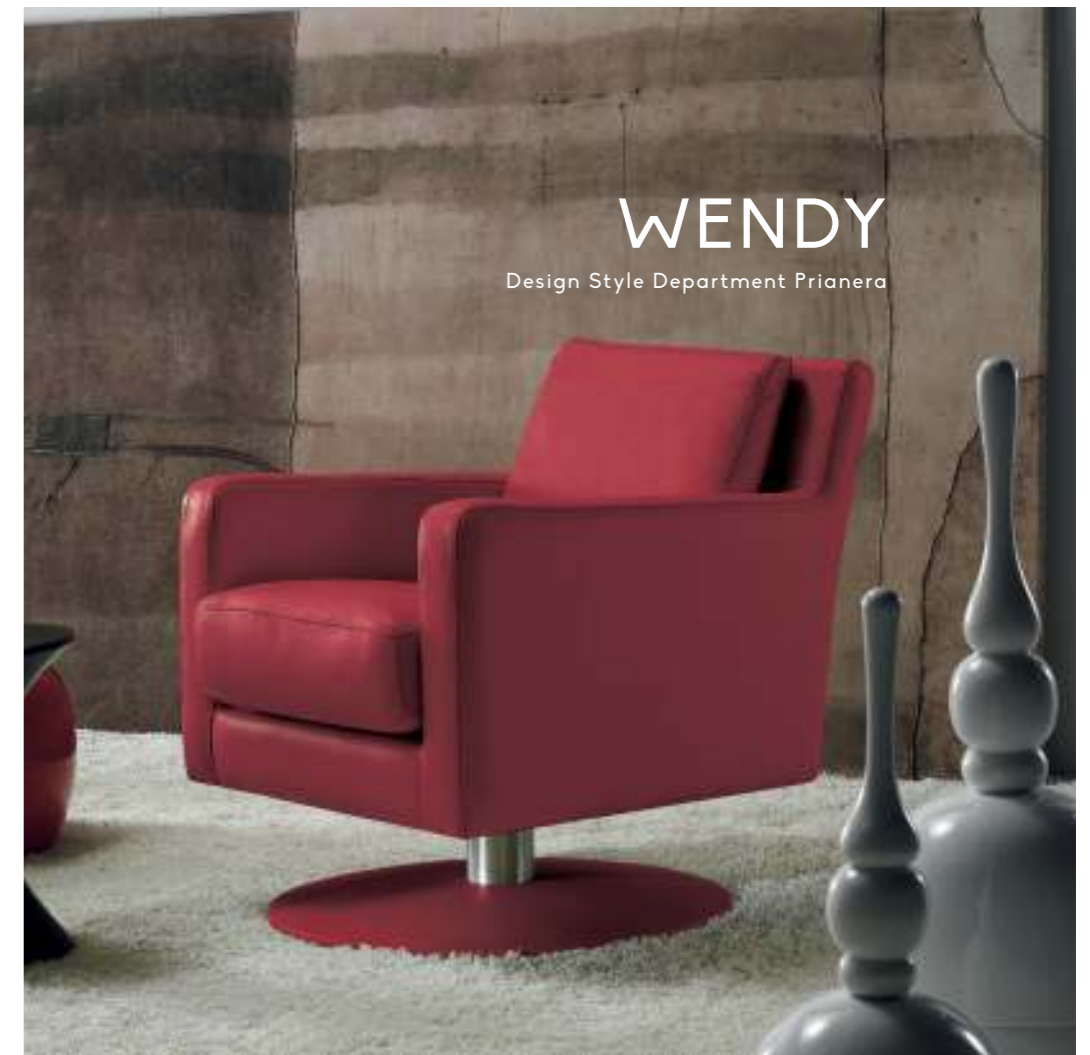

# WENDY

Design Style Department Prienera

# TULIPANO

Design Style Department Prianera



# ZOE

Design Carlo Bimbi & Carlo Sironi





TRIAL

Design Carlo Bimbi



TRIAL

Design Carlo Bimbi







## STYLE & DECOR

Nel laboratorio Prianera il pensiero è meditato e mai banale. È il luogo in cui viene coltivata la capacità di dare valore all'esperienza, in cui il tempo è necessario per costruire prodotti davvero irripetibili. Qui la costante ricerca, la competenza e le tecniche danno luogo ad un progetto innovativo ed, allo stesso tempo, affondano le radici nella migliore tradizione.

Da questa abilità, dalla coesistenza di tradizione e innovazione nascono diverse collezioni di complementi, tappeti, carte da parati, cuscini ricamati, tutti intesi come elementi funzionali e ornamentali, diversi ma associabili tra di loro in modo personale ed originale, in grado di generare una sofisticata atmosfera e di valorizzare lo spazio in cui sono inseriti.

In the Prianera Lab creative thought is always pondered with care. It is the place where ability to give value to the experience is cultivated, where time is needed to build products really unique. Here the constant research, expertise and technologies lead to an innovative project and, at the same time, root in the best tradition.

This ability and the coexistence of tradition and innovation create several collections of accessories, carpets, wallpapers, embroidered cushions, which all serve as functional elements and décor. Different but matched with each other in a personal and original way, able to generate a sophisticated atmosphere and enrich the area in which they are located.



**RICAMO 24887 B**  
Tessuto - Fabric: Ghibli col. 711  
Ricamo - Embroidery: rif. col. nabuk cacao  
Misure - Size: 55x55



**RICAMO 24887 B**  
Tessuto - Fabric: Ghibli col. 100  
Ricamo - Embroidery: tono su tono/matching  
Misure - Size: 55x55



**RICAMO 24887 B**  
Pelle - Leather: Actual marrone 6010  
Ricamo - Embroidery: rif. col. Georgia 3214  
Misure - Size: 55x55



**RICAMO 24917**  
Pelle - Leather: Stonewash Pro antracite 6050  
Ricamo - Embroidery: Silver  
Misure - Size: 55x55



**RICAMO 24887 B**  
Pelle - Leather: Stonewash Pro Forestale 6031  
Ricamo - Embroidery: tono su tono/matching  
Misure - Size: 55x55



**RICAMO 24917**  
Pelle - Leather: Stonewash Pro ecru 6002  
Ricamo - Embroidery: tono su tono/matching  
Misure - Size: 55x55



**RICAMO 24917**  
 Pelle - Leather: Nabuk moka 5010  
 Ricamo - Embroidery: gold  
 Misure - Size: 55x55



**RICAMO 24917**  
 Pelle - Leather: Bosphore bianco 4044  
 Ricamo - Embroidery: tono su tono/matching  
 Misure - Size: 55x55



**RICAMO TEXTURE 24889**  
 Pelle - Leather: Georgia tortora 3209  
 Ricamo - Embroidery: silver  
 Misure - Size: 55x55



**RICAMO TEXTURE 24889**  
 Pelle - Leather: Nabuk Moka 5010  
 Ricamo - Embroidery: Gold  
 Misure - Size: 55x55



**RICAMO 24917**  
 Pelle - Leather: Nabuk moka 5010  
 Ricamo - Embroidery: turchese  
 Misure - Size: 55x55



**RICAMO 24917**  
 Tessuto - Fabric: Ghibli col. 100  
 Ricamo - Embroidery: tono su tono/matching  
 Misure - Size: 55x55



**RICAMO TEXTURE 24889**  
 Pelle - Leather: Stonewash Pro ecrù 6002  
 Ricamo - Embroidery: tono su tono/matching  
 Misure - Size: 55x55



**RICAMO TEXTURE 24889**  
 Pelle - Leather: Stonewash Pro antracite 6050  
 Ricamo - Embroidery: Silver  
 Misure - Size: 55x55



**RICAMO 24917**  
 Pelle - Leather: Nabuk verde 5022  
 Ricamo - Embroidery: gold  
 Misure - Size: 55x55



**RICAMO TEXTURE 24889**  
 Pelle - Leather: Stonewash Pro Forestale 6031  
 Ricamo - Embroidery: tono su tono/matching  
 Misure - Size: 55x55



**RICAMO TEXTURE 24889 A**  
Tessuto - Fabric: Stonewash Pro forestale 6031  
Ricamo - Embroidery: gold  
Misure - Size: 55x35



**RICAMO TEXTURE 24889 A**  
Pelle - Leather: Stonewash Pro ecrù 6002  
Ricamo - Embroidery: tono su tono/matching  
Misure - Size: 55x35



**RICAMO TEXTURE 24889 A**  
Pelle - Leather: Georgia tortora 3209  
Ricamo - Embroidery: silver  
Misure - Size: 55x35



**RICAMO TEXTURE 24889 A**  
Pelle - Leather: Stonewash Pro antracite 6050  
Ricamo - Embroidery: silver  
Misure - Size: 55x35



standard size

H 400 cm

H 300 cm

L 120 cm



SCREEN cloud

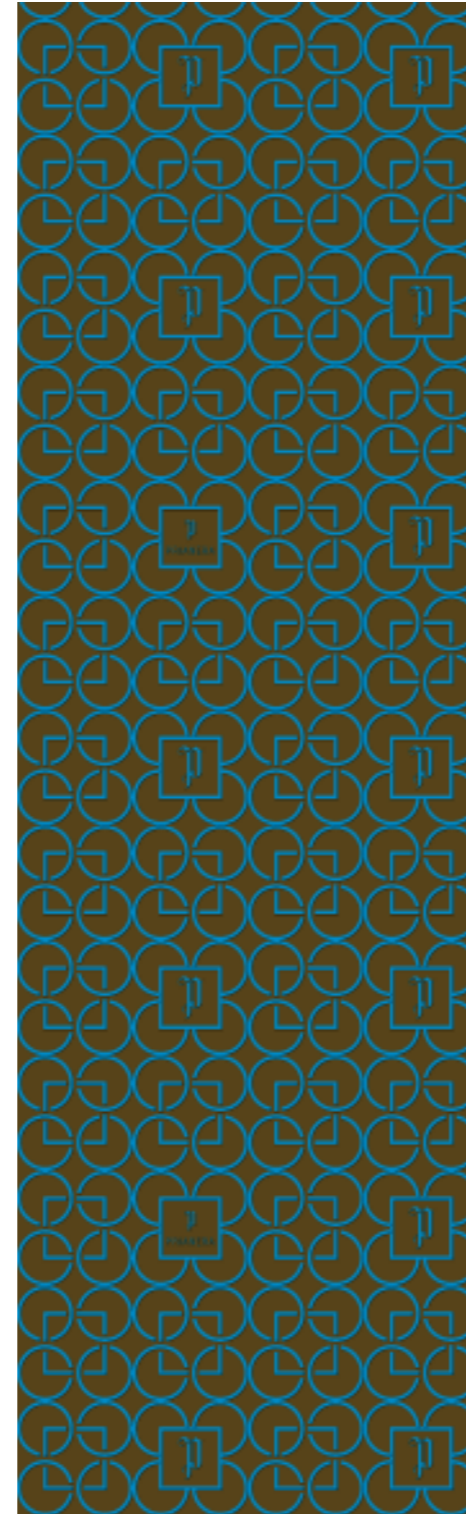

SCREEN mocha

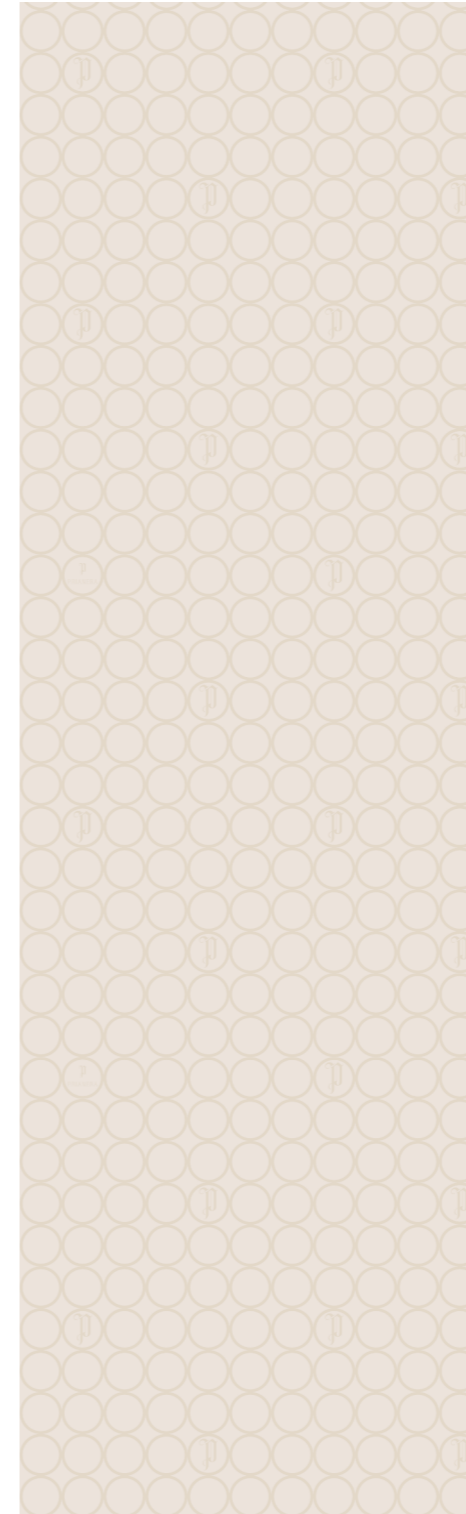

GRID sand



WILD lunar



WILD crocodile



Design Giorgio Ragazzini

TAPPETI



**BIG LOGO TUFTED grey**  
Misure - Size: 200x300



**BIG LOGO TUFTED red**  
Misure - Size: 200x300



**BIG LOGO TUFTED coffee & milk**  
Misure - Size: 200x300



**FRAME tortora**  
Misure - Size: 200x300



**LEAF sabbia**  
Misure - Size: 200x300



**FRAME mastice**  
Misure - Size: 200x300



**LEAF verde**  
Misure - Size: 200x300



**FRAME cipria**  
Misure - Size: 200x300





**MASH-UP blu**  
Misure - Size: 200x300

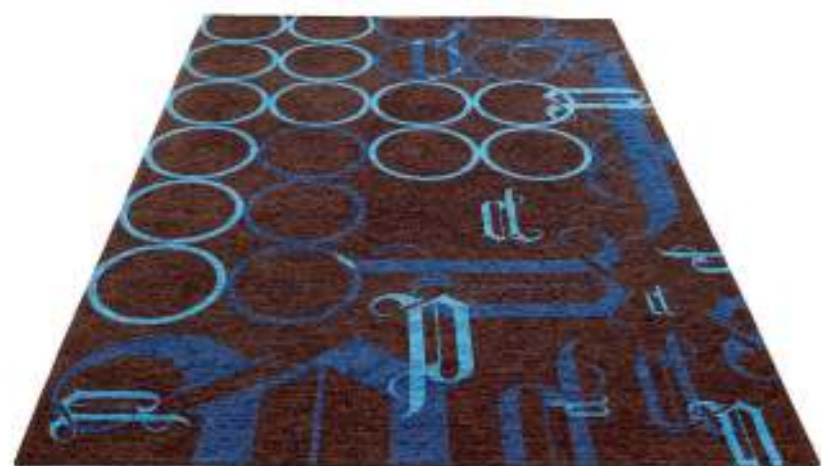

**MASH-UP turchese**  
Misure - Size: 200x300



## DIMENSIONI

La creatività e la libertà progettuale dei designer che collaborano con Polaris trovano un prezioso completamento nella preparazione tecnica del reparto sviluppo prodotti, dove nulla viene lasciato al caso: ogni singolo modello viene sviluppato tenendo conto di parametri e misure che sono il frutto di un'esperienza lunga 40 anni. La modularità e le dimensioni dei vari modelli, delle poltrone e dei complementi sono garanzia di comodità e comfort assoluti.

The creativity and the project liberty of designers that work with Polaris find a precious completion in the technical planning of R&D department, where nothing is left to chance, every single model is developed considering parameters and measures that are the result of a 40 years experience. The modularity and dimensions of various models, chairs and components are the guarantee of absolute comfort.



La prima cifra indica i centimetri, la seconda cifra indica i pollici.  
The first figure show the sizes in centimeters, the second in inches.

### Design Fabrizio Ballardini

(pp. 134/143) **ALIANTE**

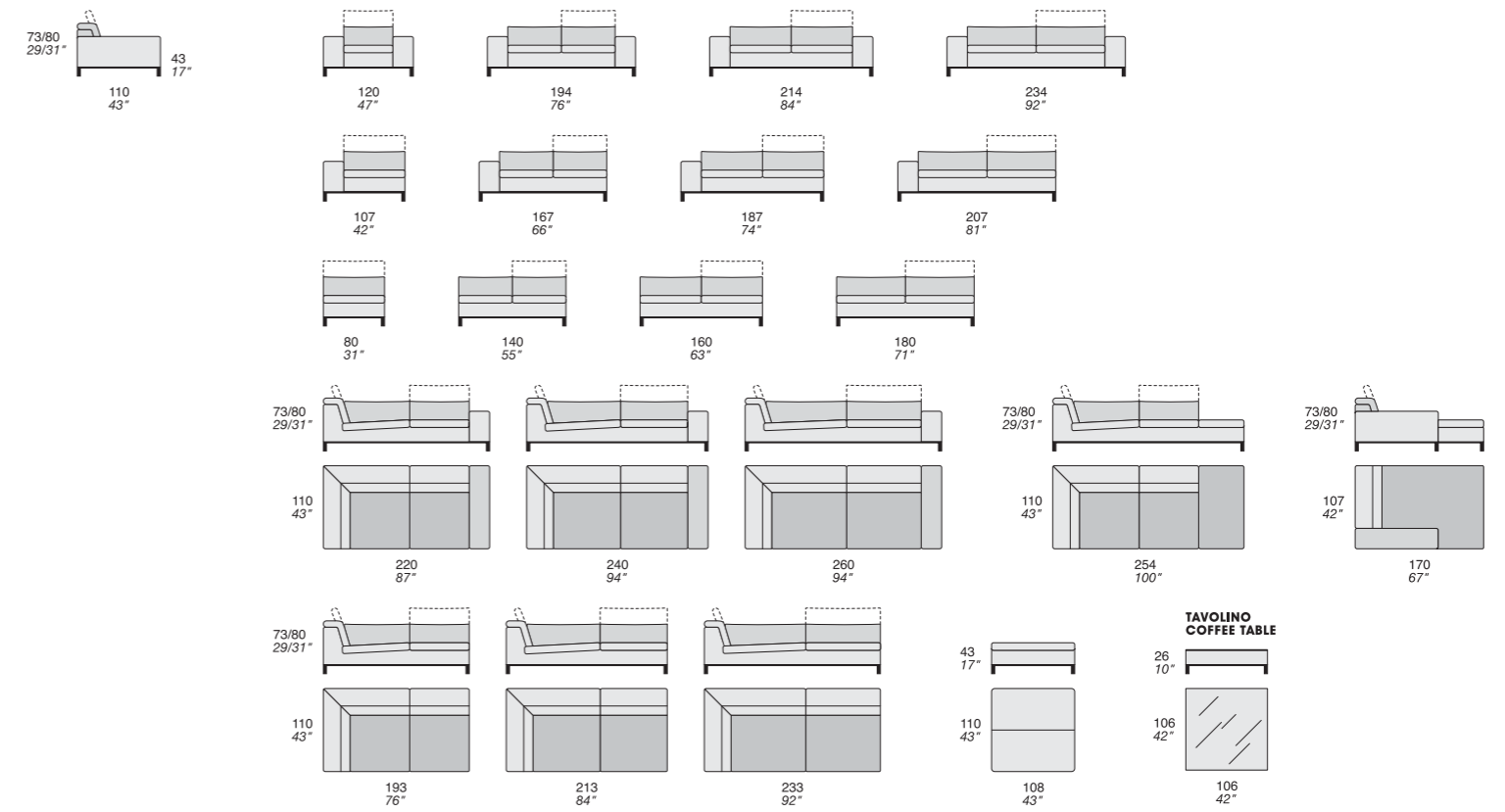

### Design Fabrizio Ballardini

(pp. 144-151) **ARIEL**

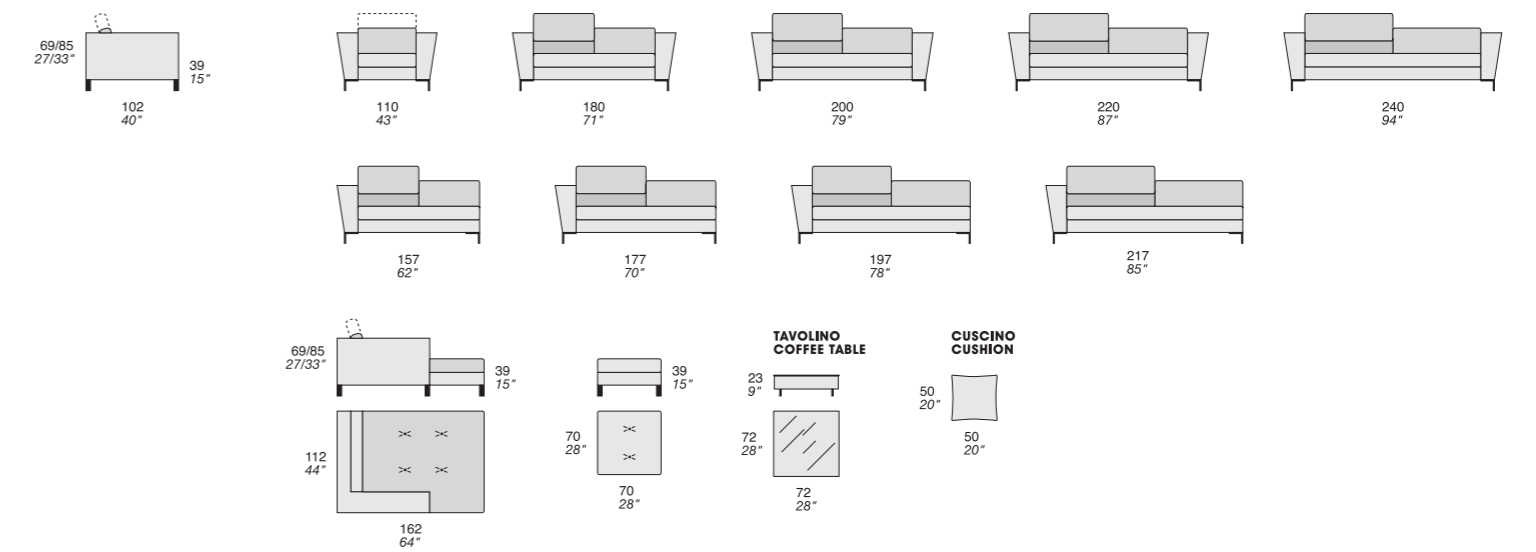

**BERNINI** (pp. 32-39)

Design Style Department Prianera

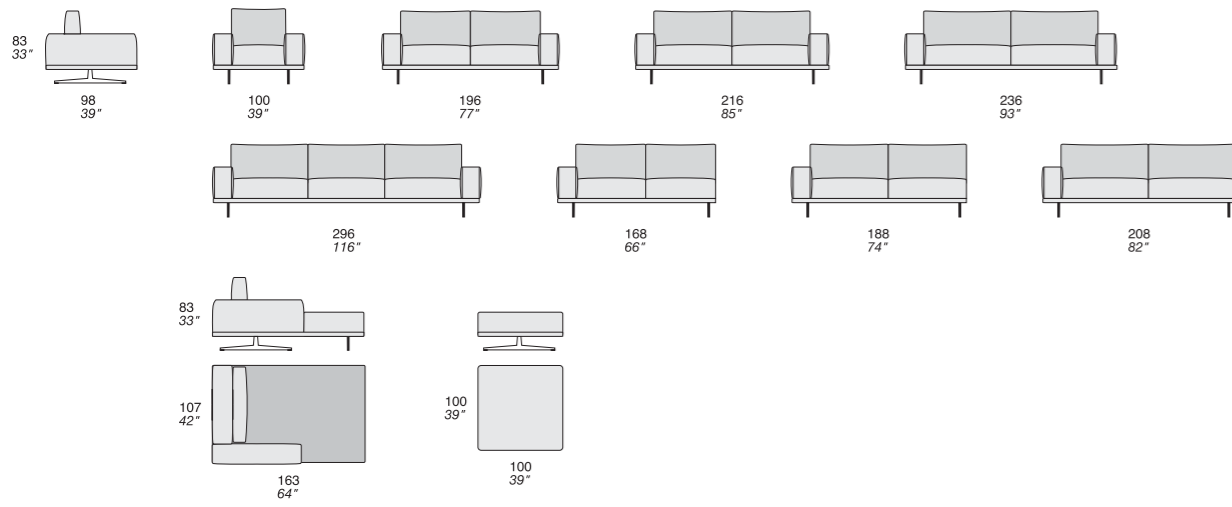

Design Carlo Bimbi & Carlo Sironi

(pp. 160-165) **DAYTIME**

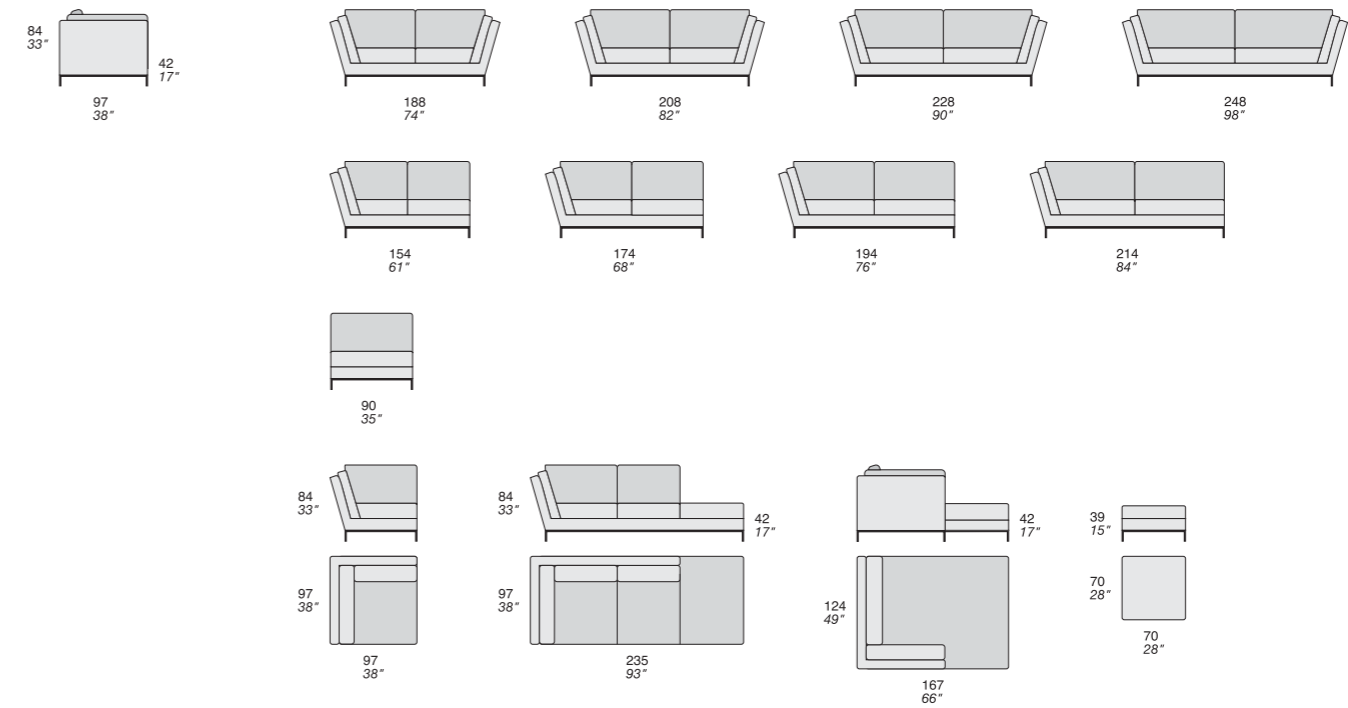

**CANOVA** (pp. 176-178)

Design Style Department Prianera

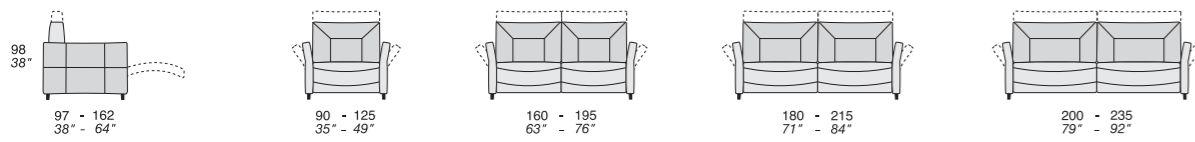

Design Carlo Bimbi & Carlo Sironi

(pp. 152-159) **FELIX**

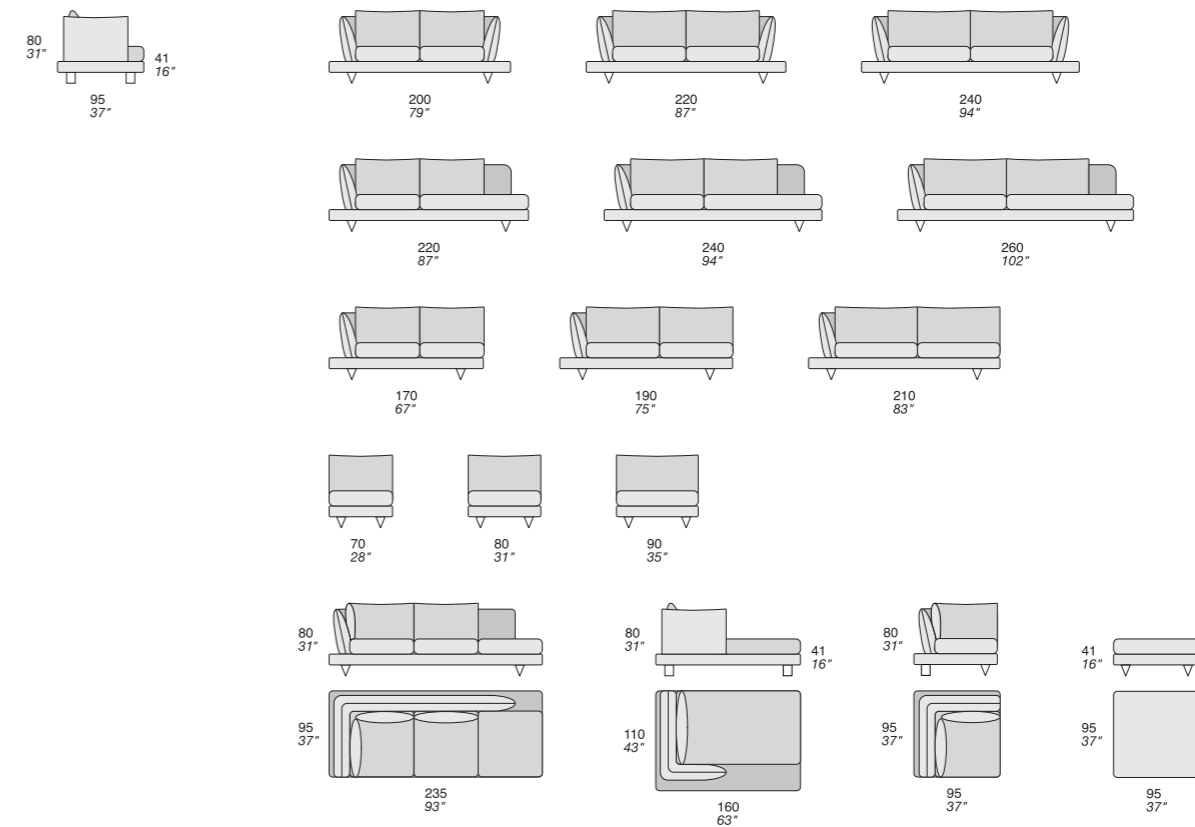

**GLAMOUR** (pp. 104-113)

Design Carlo Bimbi

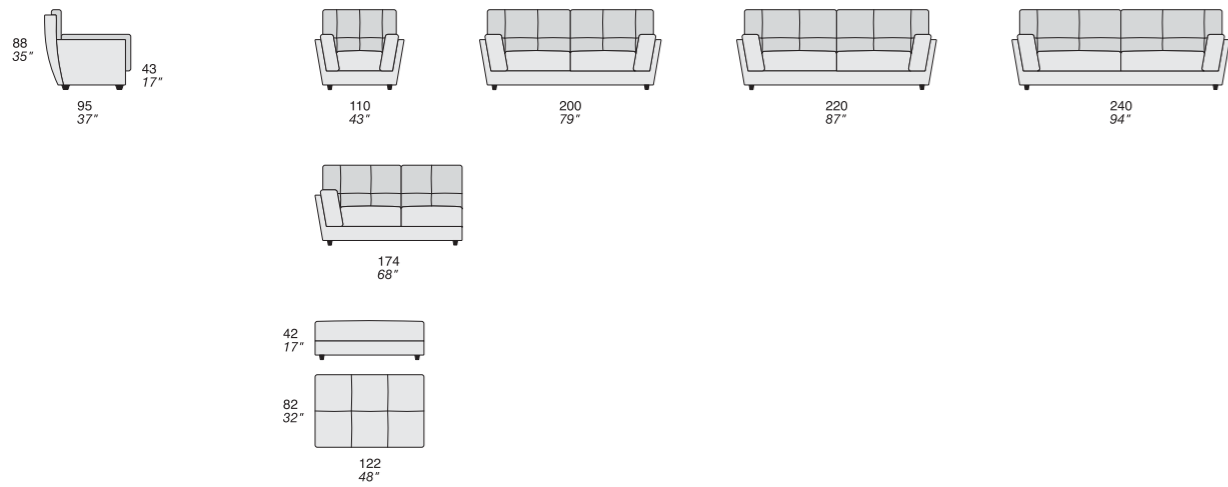

Design Style Department Priarera

(pp. 40-51) **MAYA**

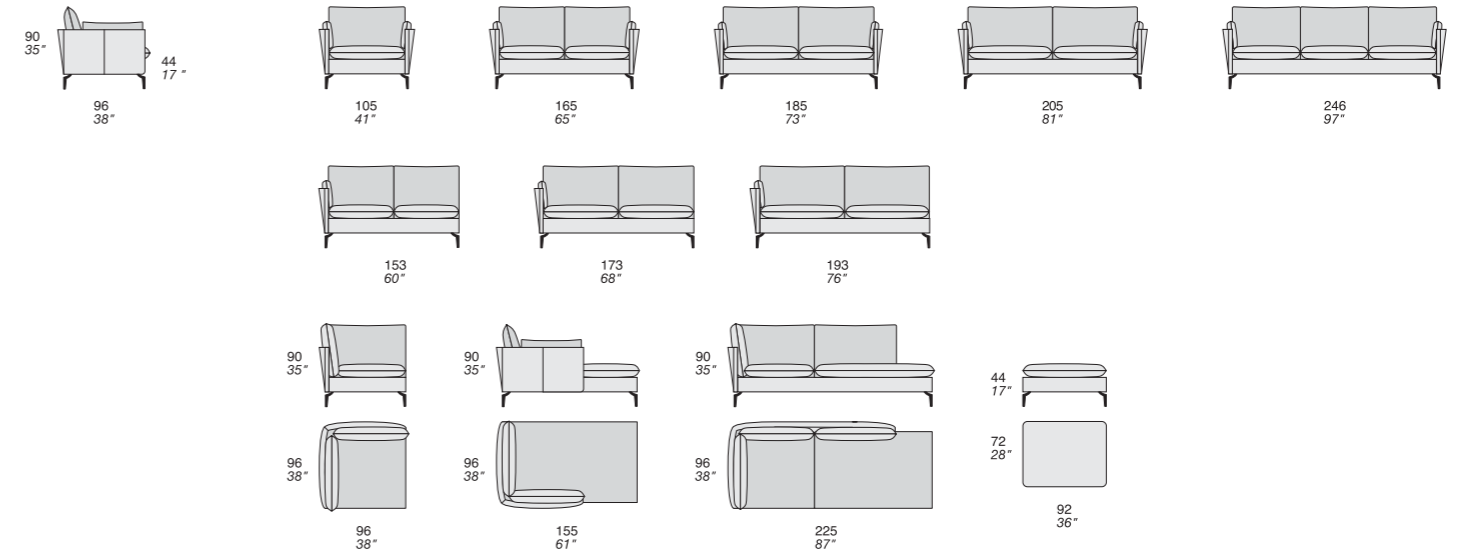

**MALAGA** (pp. 166-169)

Design Rodolfo Bertozzi

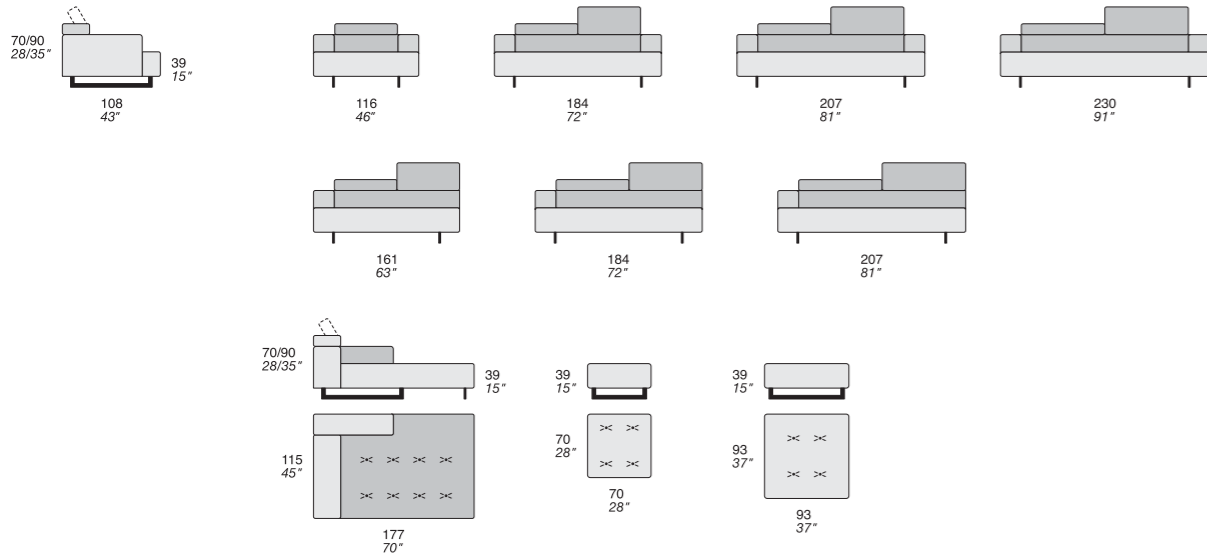

Design Angelo Tomaiuolo

(pp. 52-61) **MIVIDA**

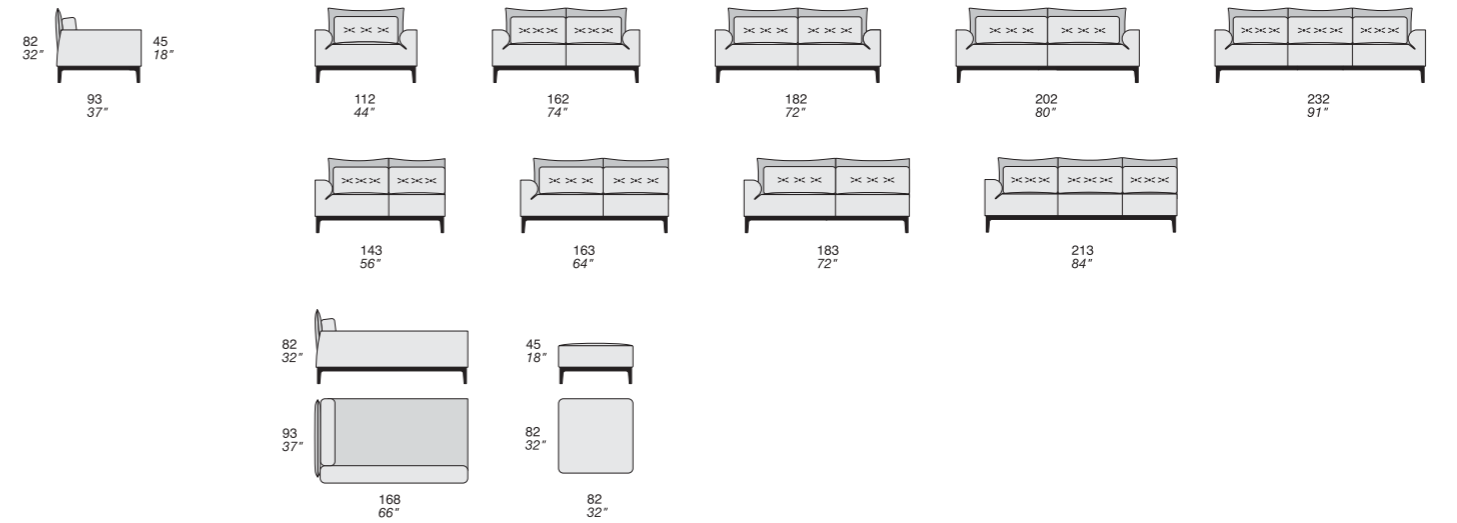

**MODÍ** (pp. 18-31)

Design Style Department Priarera

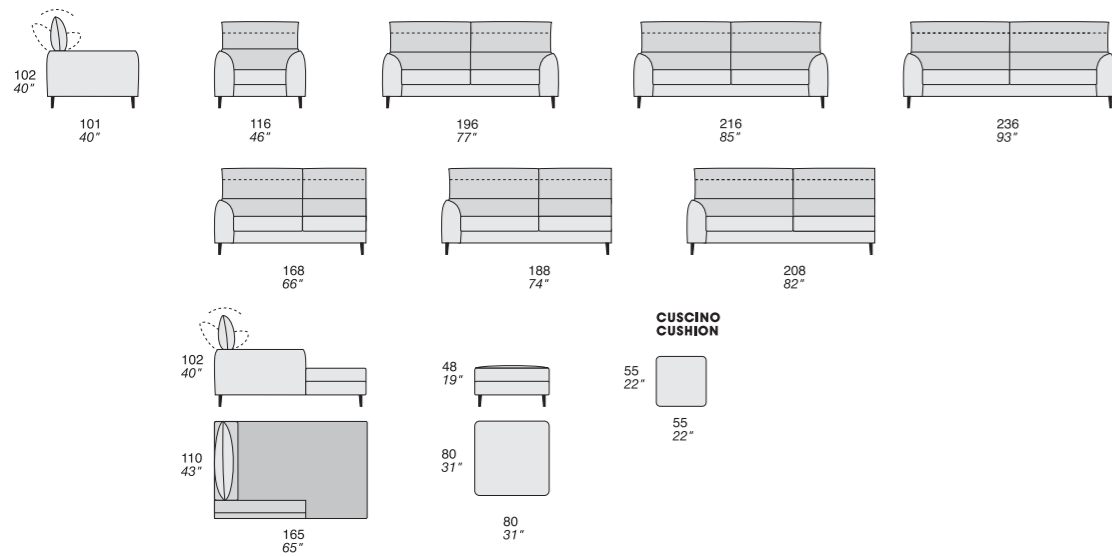

**MOOD** (pp. 98-103)

Design Fabrizio Ballardini

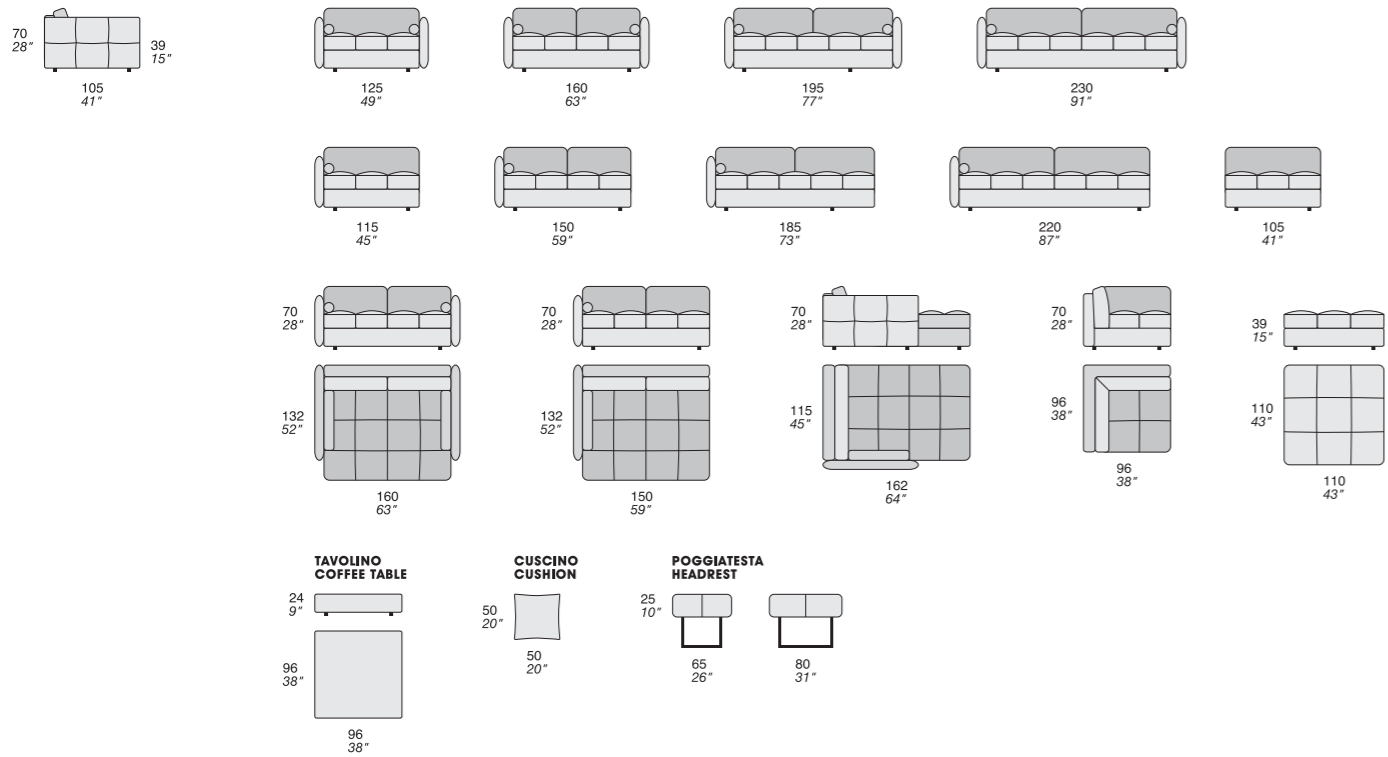

Design Enrico Cesana

(pp. 118-127) **NESTING**

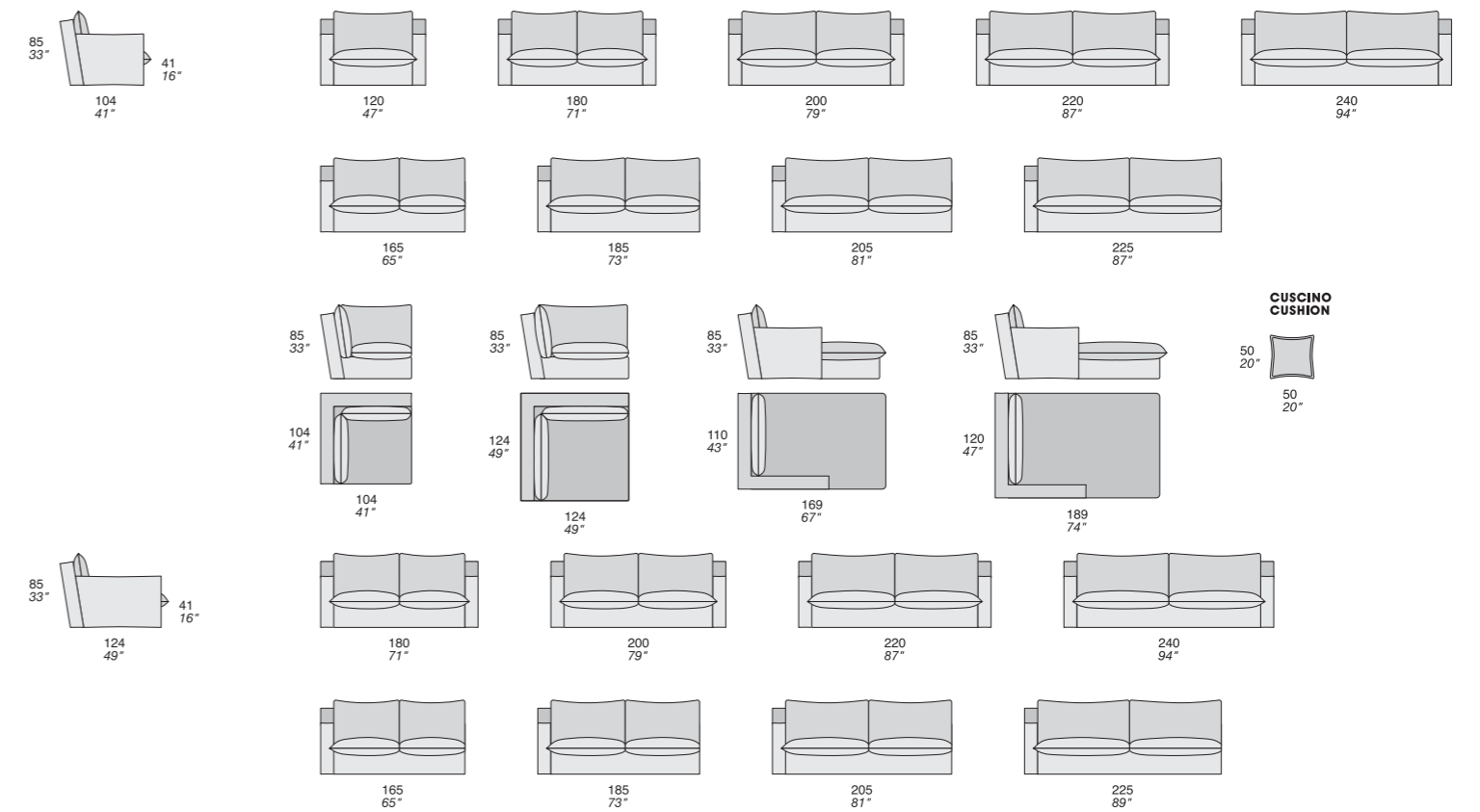

Design Fabrizio Ballardini

(pp. 90-97) **NILO**

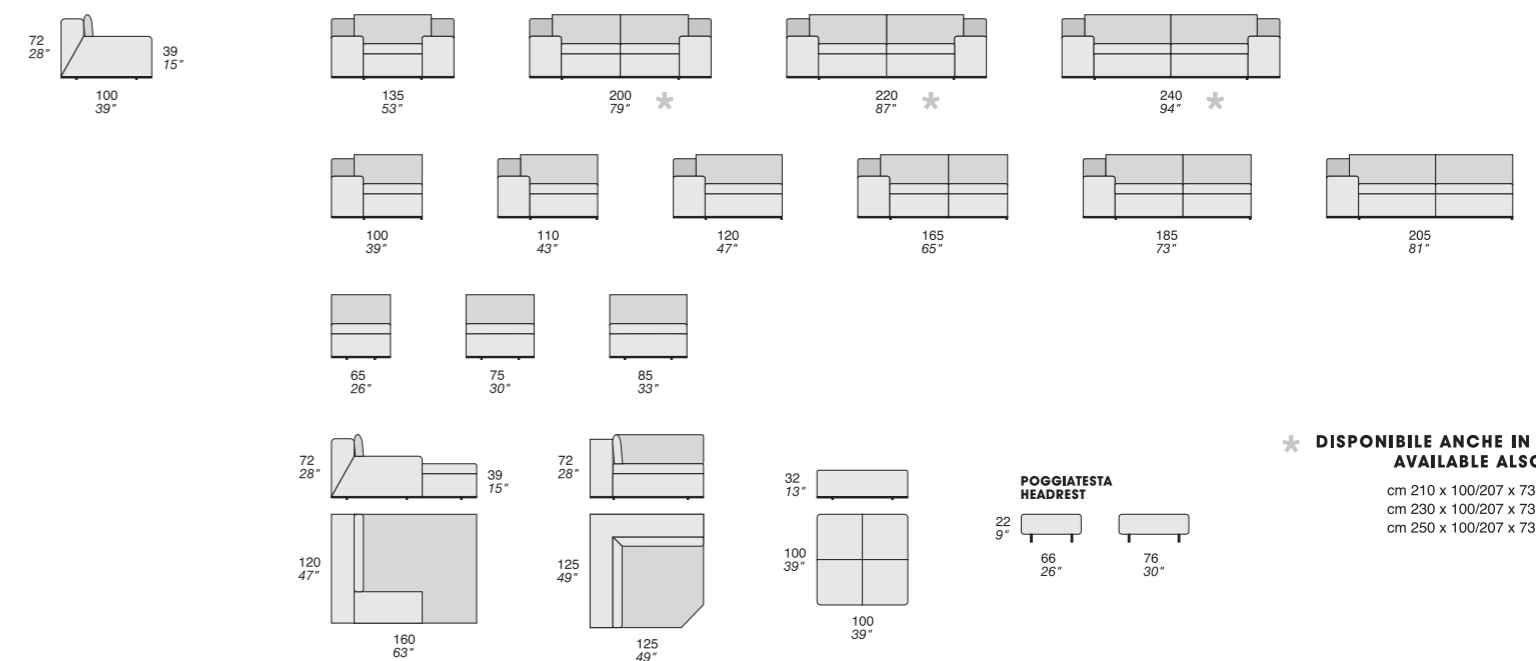

\* **DISPONIBILE ANCHE IN VERSIONE LETTO**  
**AVAILABLE ALSO IN BED VERSION**

cm 210 x 100/207 x 73 - inch 83 x 39/82 x 29  
cm 230 x 100/207 x 73 - inch 91 x 39/82 x 29  
cm 250 x 100/207 x 73 - inch 98 x 39/82 x 29

**SHARPEI** (pp. 80-89)

Design Fabrizio Ballardini

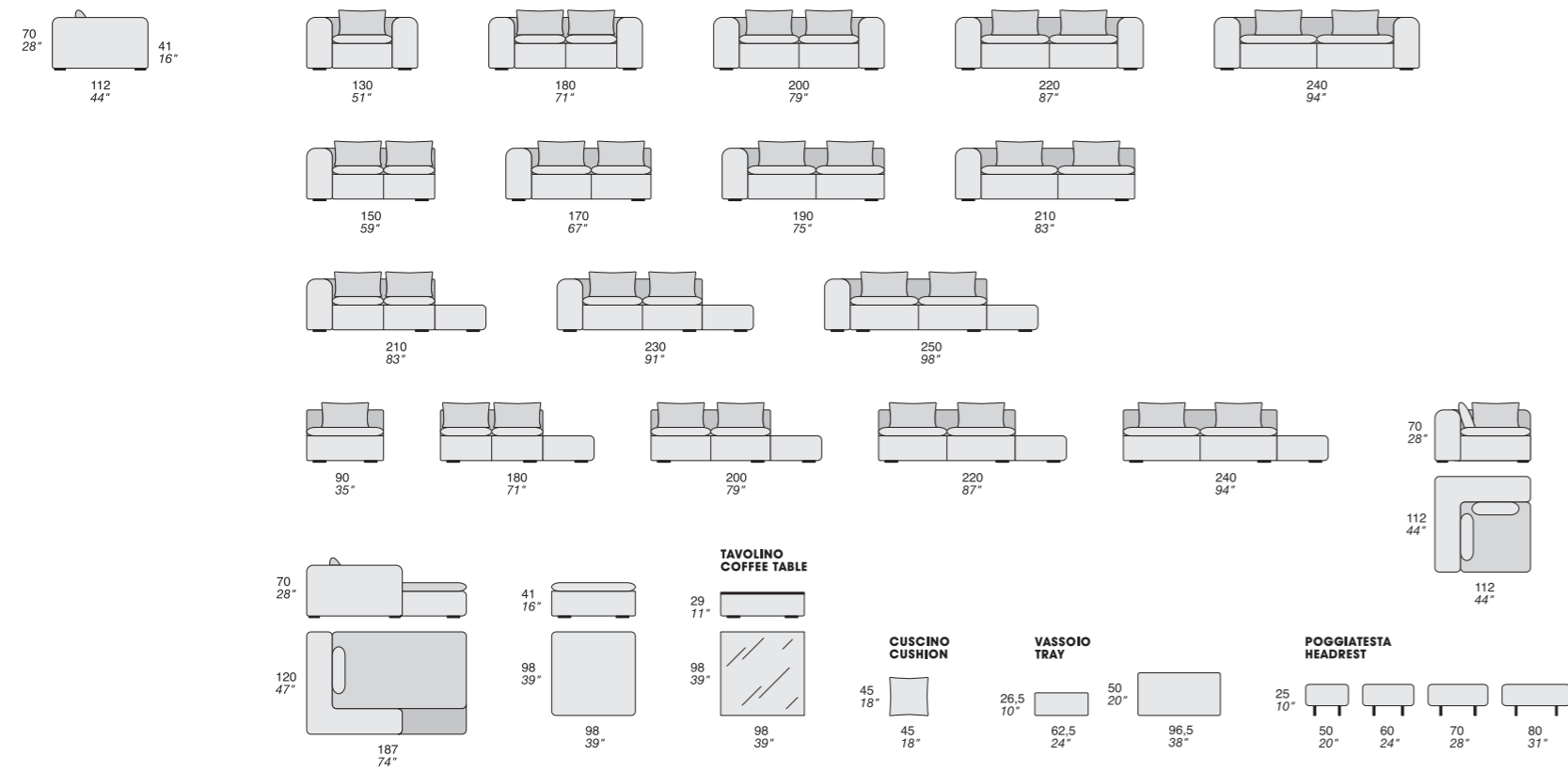

(pp. 170-175) **SORRENTINO**

Design Style Department Priarera

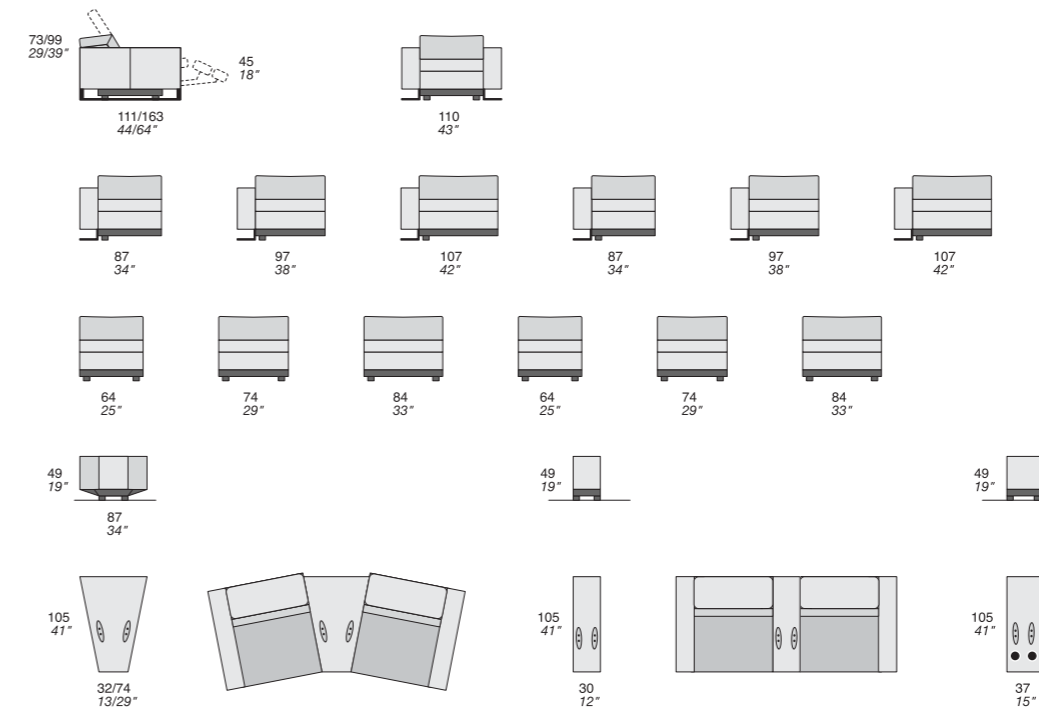

**SONORA** (pp. 114-117)

Design Fabrizio Ballardini

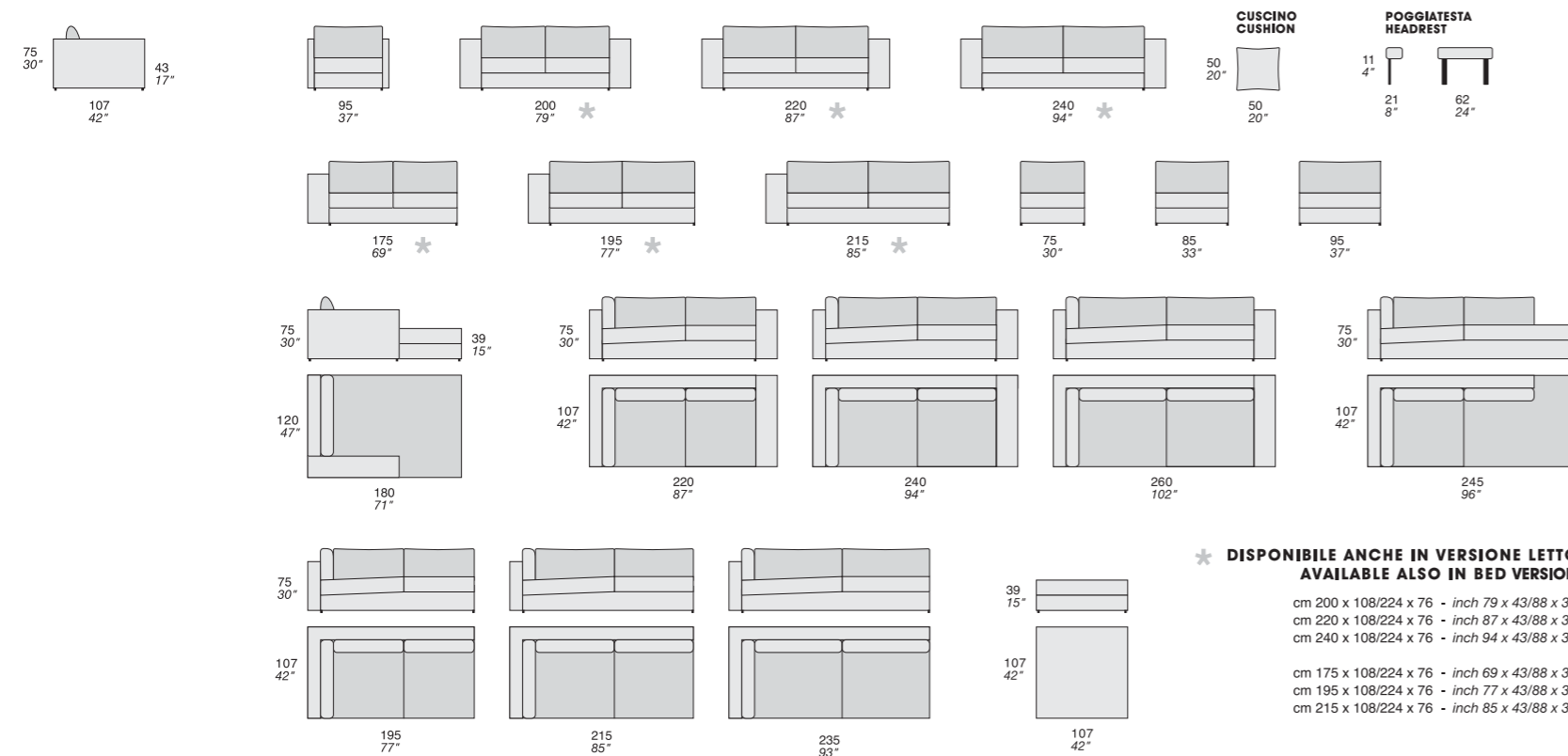

\* DISPONIBILE ANCHE IN VERSIONE LETTO  
AVAILABLE ALSO IN BED VERSION

cm 200 x 108/224 x 76 - inch 79 x 43/88 x 30  
cm 220 x 108/224 x 76 - inch 87 x 43/88 x 30  
cm 240 x 108/224 x 76 - inch 94 x 43/88 x 30

cm 175 x 108/224 x 76 - inch 69 x 43/88 x 30  
cm 195 x 108/224 x 76 - inch 77 x 43/88 x 30  
cm 215 x 108/224 x 76 - inch 85 x 43/88 x 30

**BRACCIOLO PROVVISTO DI PORTA USB**  
ARMREST EQUIPPED WITH USB PORT



**BRACCIOLO CON 2 VANI REFRIGERATI**  
ARMREST WITH 2 REFRIGERATED COMPARTMENTS



**TANGRAM UP** (pp. 128-133)

Design Enrico Cesana

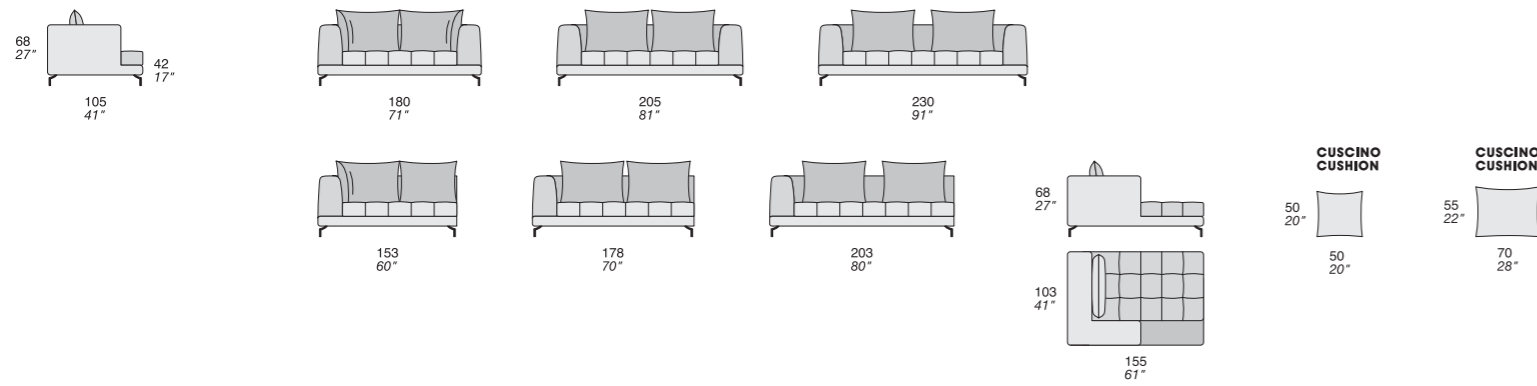

Design Fabrizio Ballardini

(pp. 72-79) **YUCATAN**

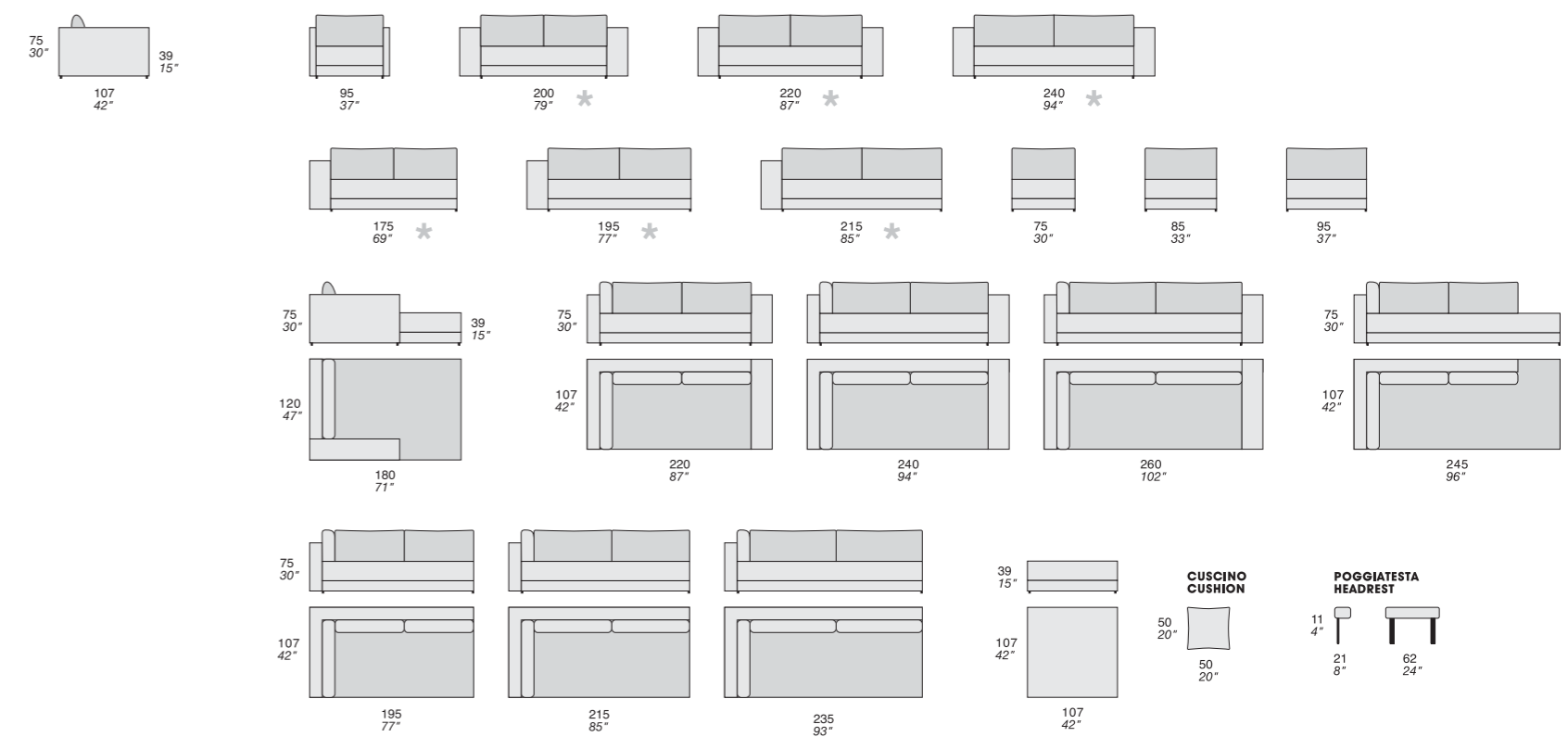

**VEGA** (pp. 62-71)

Design Style Department Priarera

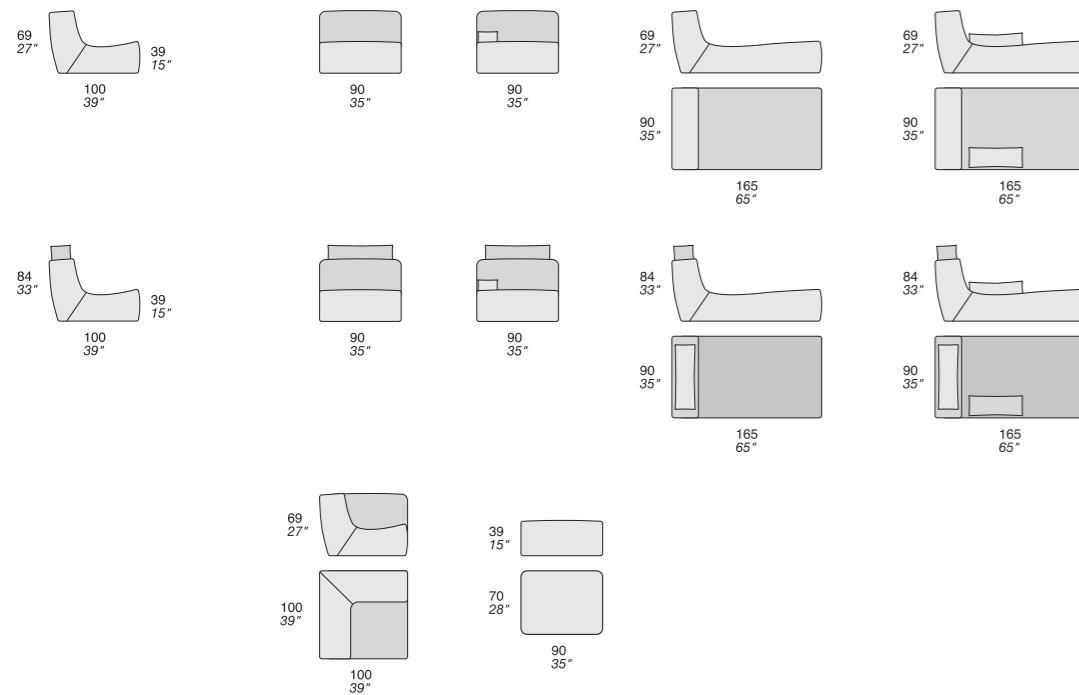

**\* DISPONIBILE ANCHE IN VERSIONE LETTO**  
**AVAILABLE ALSO IN BED VERSION**

cm 200 x 108/224 x 76 - inch 79 x 43/88 x 30  
cm 220 x 108/224 x 76 - inch 87 x 43/88 x 30  
cm 240 x 108/224 x 76 - inch 94 x 43/88 x 30

cm 175 x 108/224 x 76 - inch 69 x 43/88 x 30  
cm 195 x 108/224 x 76 - inch 77 x 43/88 x 30  
cm 215 x 108/224 x 76 - inch 85 x 43/88 x 30



## POLTRONCINE (pp. 180-189)

### ALICE

Design Carlo Bimbi & Carlo Sironi

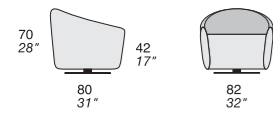

### FLORENCE

Design Style Department Prianera

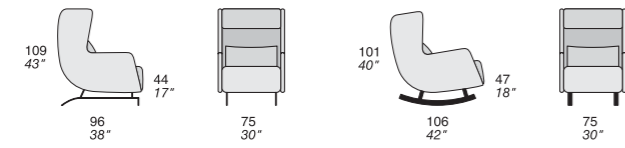

### KAREN

Design Carlo Bimbi & Carlo Sironi

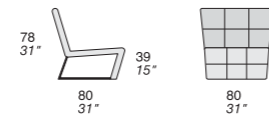

### KLAB

Design Carlo Bimbi & Carlo Sironi

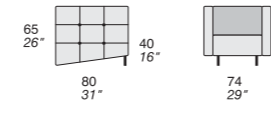

### LOTO

Design Carlo Bimbi & Carlo Sironi

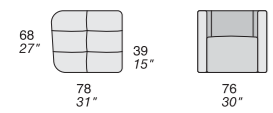

### NORA

Design Fabrizio Ballardini

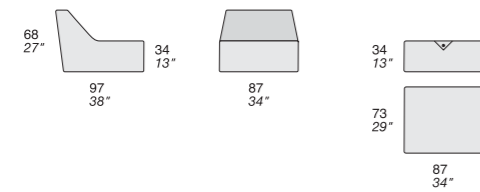

### TULIPANO

Design Style Department Prianera

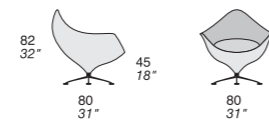

### WEBY

Design Fabrizio Ballardini

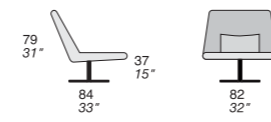

### WENDY

Design Style Department Prianera

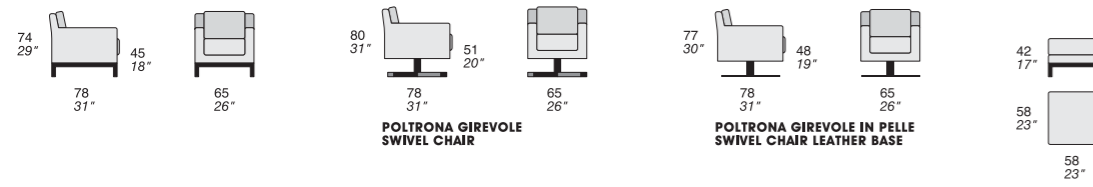

POLTRONA GIREVOLE IN PELLE  
SWIVEL CHAIR

POLTRONA GIREVOLE IN PELLE  
SWIVEL CHAIR LEATHER BASE

### ZOE

Design Carlo Bimbi & Carlo Sironi

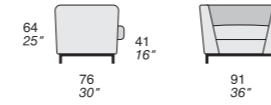

## TAVOLINI (pp. 190-195)

### LIBRIS

Design Style Department Prianera

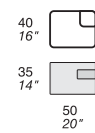

### FREELINE

Design Style Department Prianera

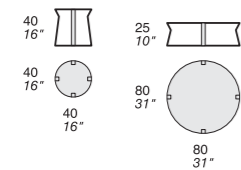

### MAX

Design Carlo Bimbi

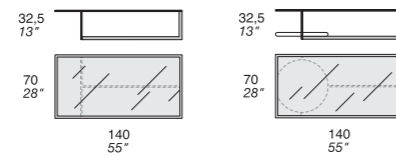

### MEMPHIS

Design Style Department Prianera

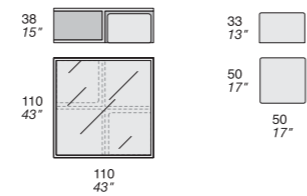

### ROUND

Design Style Department Prianera

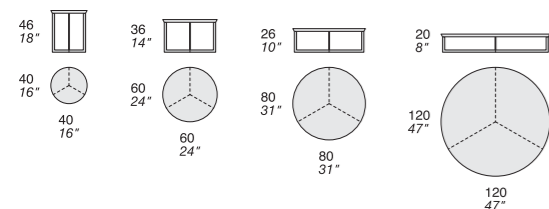

### TRIAL

Design Carlo Bimbi

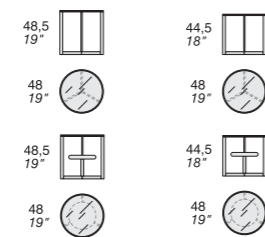

### TRIBAS

Design Carlo Bimbi

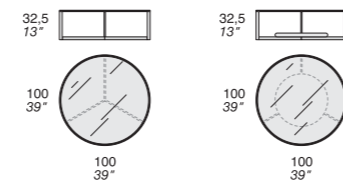

Colori laccati per tavolini ROUND, FREELINE, LIBRIS

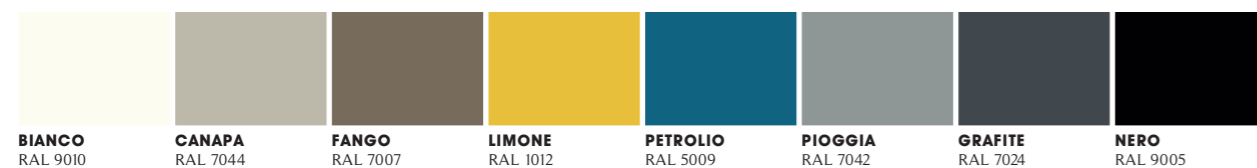



## CREDITI

---

**Direzione e coordinamento**/Andrea Rasi

**Grafica**/Studio Ragazzini

**Foto**/Giovanni Collina Aeroplano/Leonfoto.it/

Eolo Radoni Photography

**Prestampa**/Studio 59

**Stampa**/Modulgrafica forlivese

---

L'azienda si riserva di apportare modifiche ai prodotti che ritiene più opportune, in qualsiasi momento e senza preavviso.

Alcuni accessori presenti nelle immagini fotografiche non sono prodotti dalla ditta Polaris Sas, si prega di far sempre riferimento al listino prezzi.

È vietata ogni riproduzione totale o parziale in Italia e all'estero.

Polaris reserves the right to modify models and dimensions without any previous notice.

Some accessories present in the photographs are not produced by Polaris Sas, please refer to price list.

Total or partial reproduction prohibited in Italy or any other country.



PRIANERA®

---

**PRIANERA** by **POLARIS designed for living srl**

Via Euclide, 8 - 47121 Forlì (FC) - Italy

Tel. +39 0543 1716055 - Fax +39 0543 1716073

info@prianera.it - www.prianera.it